



Installation

SnowWhite² v2020-05

beta version

index

SnowWhite ² dimensions and weight.....	2
Technical specification SnowWhite ²	3
Hardware.....	3
Software.....	3
Features.....	3
Connections.....	4
Electric supply.....	4
Gas.....	4
Suggested equipment.....	5
Fume extractor.....	5
Safety.....	5

SnowWhite² dimensions and weight

printer	1500 x 604 x 520 mm (59x23,7x20,4 inc)	130 kg approx
pallet box	1800 x 1200 x 800 mm (71x47x31,5 inc)	180 kg approx

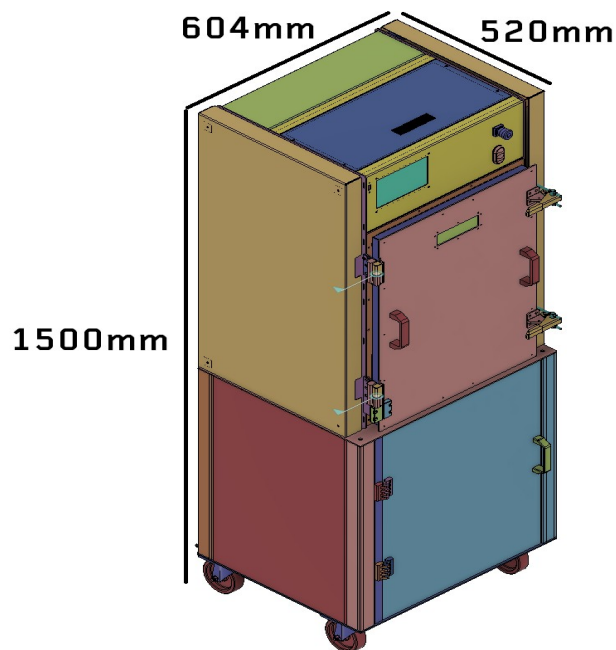

Recommended working area 150x150cm (59x59")

The printer is on wheel but arrive in a wooden box on a pallet, you need a forklift or trans pallet to handle it.



Technical specification SnowWhite²

Hardware

Laser Power 14 Watt CO2
Laser speed range up to 64,000 pps (<3.500 mm sec)
Powder temperature up to 190°C
Chamber temperature up to 180°C
Thermocouple and IR sensor
Build area 100 x100 x 90 mm (3,9x3,9x3,5 inc)
X Y resolution up to 100 micron
Layer Z from 50 micron
Print speed in Z up to 15 mm hour
Power max consumption 1.5KW
Dimensions 150x60x52cm (59x23,7x20,4 inc)
Weight 130 Kg
Certification CE (in progress)

Software

Slicing software included
Source file STL

** tech specification can change due to technical reasons

Features

Tank powder from 200g to 1.5 Kg
Minimum powder required to print 250-300g
Open machine concept
Standard gcode



installation (English)

When the printer arrives, check if the packaging is intact, both the superior and the lower wooden parts, otherwise write a conditionally accept on delivery note of the carrier.

Remove the printer from the packaging keeping the original packaging then place the machine in the chosen location.

Follow the instructions included with the printer. In case of need, contact snowwhite@sharebot.it.

You will be contacted to continue the installation process.

Connections

Electric supply

230 volt single-phase 50/60 Hz 16 Ampere,

power max consumption 1,5 kw

AC power inlet IEC C20

Grounding

Gas

The connection to the machine is made with an internal 6 mm (0.24 in) tube 4 mm (0,15 in) , through a 6 mm tube-tube bulkhead fitting

ex: <https://it.rs-online.com/web/p/products/3633603/>

es en: <https://uk.rs-online.com/web/p/pneumatic-bulkhead-tube-to-tube-adaptors/9160823/>

The gas must reach the entrance of the machine with a required minimum pressure of 3 bar (43.5psi) up to a maximum of 8 bar (116psi).

Gas consumption at start is about 420 l/h, during work it is about 175l/h.

If the gas leaving the machine is to be dispersed through a drain line, it is possible to connect the latter to the discharge pressure located in the back of the machine next to the gas inlet, the connector is the same size of 6 mm external and 4 mm internal pipe.



Suggested equipment

Vacuum cleaner

Sieve for powder

Sandblaster

Internet connection for support and upgrade.

Fume extractor

Depending on powder used is recommended fume extractor generated during the process

Safety

It is mandatory to read the safety data sheets of the gas and powders and to follow the instructions and the precautions here described.